

Premier Acoustic Product Datasheet



X02 SERIES SYSTEMS



System:	2 way full duplex
Speakers:	15W high quality full range 3.0 inch diameter, 7W 2½ inch diameter
Microphones:	Electret condenser microphone (directional).
Amplifiers:	O/P power: 15W r.m.s. (each amplifier) S/N ratio: 60dB
Freq. response:	20Hz – 20KHz
Distortion:	0.05%
Operation:	Class B increased headroom design
Heat dissipation:	1 watt each amplifier
Reverb time:	<100mS
Sound level:	<60dBA
Mains Supply:	180-260V 50/60Hz (110V optional)
Electrical Safety:	To comply with BS 415 and all CE regulations
Material:	Mild steel or stainless steel
Colours:	Grey or Black
* Adjustments:	Parallel and differential gain
* Options:	Mute switch (for clerk's privacy). On/off switch. Call button. Induction loop facility can be included.

Premier Acoustic Ltd, Unit 9, Sedgley Trading Estate, Sedgley Park,
Prestwich, Manchester M25 9WS

Tel: 0161 798 6336 Fax: 0161 798 6226

Premier Acoustic Product Datasheet



X02 SERIES SYSTEMS

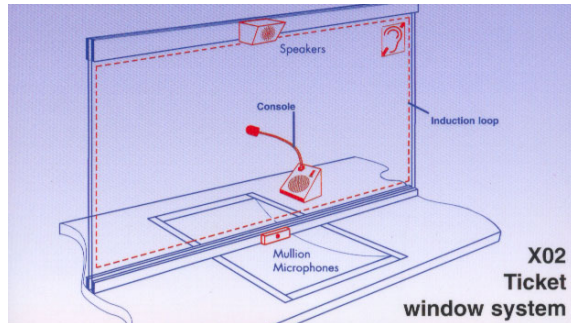
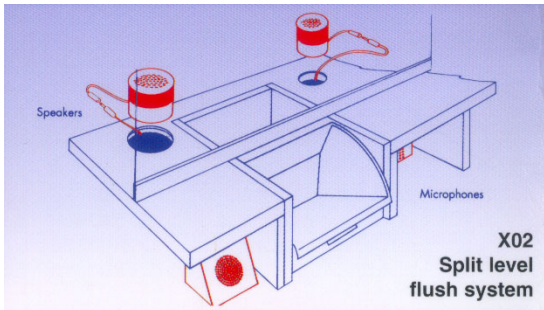
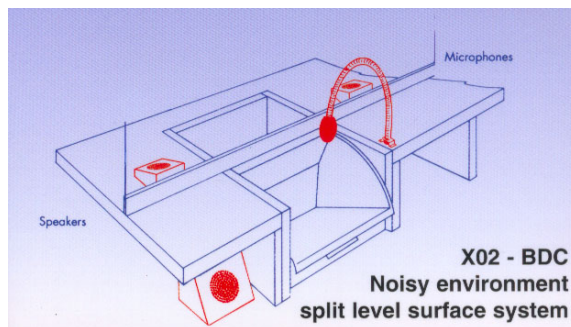
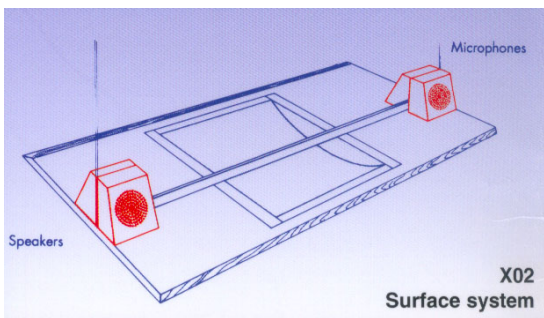
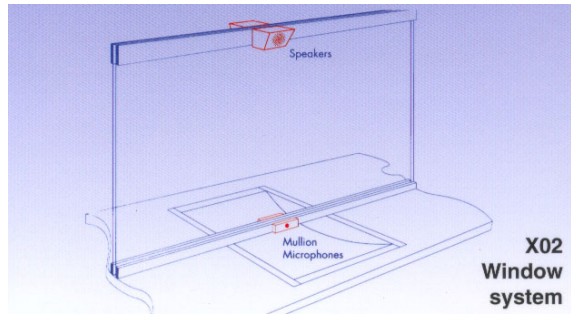
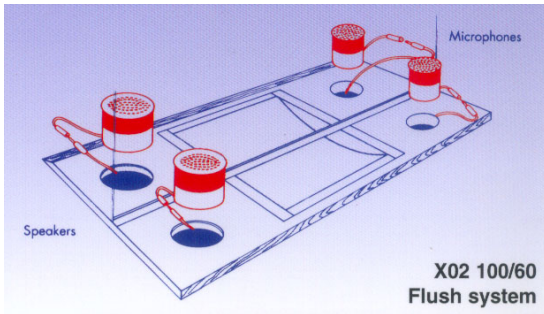

Premier Acoustic Ltd, Unit 9, Sedgley Trading Estate, Sedgley Park,
Prestwich, Manchester M25 9WS

Tel: 0161 798 6336 Fax: 0161 798 6226